ECOSTEP® 100

Safety Instructions

Technical Specification

Installation

Safety Instructions

General



All transportation, storage, assembly, installation, connection, commissioning and service work must only be carried out by qualified skilled personnel taking the following into account: the relevant documentation, regulations and requirements pertaining to the equipment concerned as well as national and regional safety and accident prevention regulations.

Qualified skilled personnel are persons who have a relevant vocational qualification and have proper knowledge of the execution of the above-mentioned work.



Read the documentation carefully before installation and commissioning. Serious injury to persons and equipment may result through improper use of the device or incorrect installation or operation. All technical specifications and conditions must be adhered to in all cases.

- The device contains electrostatic sensitive components, which may be damaged by improper handling. Discharge yourself before you touch the device. Avoid contact to high isolating materials (e.g. synthetic fibres, plastic films, etc.).



Control and power connectors may be energized even when the motor does not move. All electrical connectors of the device must not be neither plugged in nor disconnected under voltage since electric arcs may damage persons and connectors.



Do not touch components which are energized during operation immediately after disconnection from supply. Wait after disconnection of the device from the power supply at least 6 minutes before you touch components which are energized during operation. The DC-Bus capacitor remains charged to dangerous voltages up to 6 minutes after power-off. This time could be higher depending on the external power supply. For your safety, measure the DC-Bus voltage and wait until it is lower than 40V.

Proper Use

The device ECOSTEP is intended for use in commercial equipment and comply with the applicable standards and regulations and meets the requirements of the Low Voltage Directive 73/23/EEC. All technical specifications and permissible conditions mentioned in the documentation must be adhered to in all cases. The device ECOSTEP is a component intended for installation in machinery. Commissioning (starting operation in accordance with the intended use) is prohibited until such time as the machine's conformity with EMC Directive 89/336/EEC and Machinery Directive 89/392/EEC has been established (note EN 60204).

The following are prohibited, unless expressly provided otherwise:



use in hazardous areas
use near oils, acids, gases, vapours, dust, radiation, etc.

Guidelines for Mounting and Installation



Upon mounting and installation, note the following points:

- ensure that the equipment is installed on a suitable, low-vibration substructure or in an electric cabinet,
- allow unhindered ventilation,
- make sure there is sufficient clearance between adjacent units,
- be careful when handling components to avoid injury to persons or equipment (do not touch, bend or damage electronic components and contacts, do not change isolating clearances).

Electrical Connection



All installation instructions mentioned in the documentation must be considered. All work must be carried out only when

- the electric equipment is disconnected from the power supply and prevented from being switched on accidentally,
- you have double-checked that the equipment is de-energized
- you have ensured that any additional monitoring and protective features are properly installed.

When connecting the equipment to the power supply, ensure that

- the applicable standards and regulations are complied with,
- the power connections are permanently secured,
- the EMC-compliant installation (e.g. screening, earthing, arrangement of filters and laying of cables) is realized.

Note that the machine manufacturer is responsible for the compliance of the final machine with all limits of the valid EMC regulations.

Operation



Do not disable monitoring and protective features during the trial run. Covers, electric cabinet doors etc. must always be closed during operation. In the event of changes in the operating state, switch off the equipment in case of doubt and try to establish the cause. Contact the manufacturer if necessary.

Further documentation for software commissioning and operation



For software commissioning of the ECOSTEP100, follow the guideline “Software Commissioning ECOVARIO and ECOSTEP” which is provided on the CD-ROM delivered together with the device. Furthermore, you will find documentation on operation and application of the ECOSTEP100 on this CD-ROM.

Technical Specifications

Operating Modes

Online positioning drive by fieldbus	RS232, CAN (Version AA) or RS232, RS485 (Version LA)
Positioning drive by PLC interface	digital PLC I/O
Positioning drive by pulse/direction	RS422, 24 V or 5 V signals
Speed controller by analog command	10 Bit analog input
Master/Slave positioning drive	RS422 or 24 V encoder signals

Controller Loop Data

Sampling time digital speed loop	0.25 ms (4 kHz)
Sampling time digital position loop	1.0 ms (1 kHz)

Power Stage Specifications

Max. RMS phase current	5.6 A _{rms}
Max. phase current	8 A _{DC}
Max. output voltage	U _{DC-BUS}
Max. output power	0.5 kW
Short-circuit protection of motor output	motor phases to DC-BUS and amongst
Min. inductance of motor winding	0.5 mH
Length of motor cable	max. 10 m (otherwise consult supplier)
Frequency of output current ripple	16.4 kHz

Electrical Specifications

Control logic supply	18 ... 30 V DC, ripple < 10%
Fuse of control logic supply (recommended)	3 A T
Bus power supply (U _{DC-BUS})	24 ... 70V _{DC}
Fuse of bus power supply (recommended)	10 A T

Operating Conditions

Operating temperature	0 ... 40°C
Storage temperature	-10 ... 70°C
Humidity (non-condensing)	5 ... 95% (RH-2 according to IEC 61131-2)
Pollution degree	2 (according to IEC 61131-2)
Protection class	IP20
Place of installation	dust-free, dry, lockable (e.g. electrical cabinet)
Mounting position	vertical (refer to "ECOSTEP Installation")
Installation altitude	up to 1000 m above sea level (full ratings)
Power loss dissipation: @ 5,6 A _{rms} (U _{DC-BUS} ≤ 70V)	≤ 20 W
Cooling	Installation on mounting plate

Mechanical Specifications

Housing	aluminium, passivated, conforming to RoHS
Dimensions (H x W x D mm)	200 x 87 x 50 (without mating connectors)
Mass	0.5 kg
Cable mounting and strain relief	metal clips, max. cable diameter 15 mm
Connector fieldbus (X1) - Version AA (CAN) - Vrsion LA (RS485)	Sub-D 9-pole plug (male) Sub-D 9-pole socket (female)
Connectors for: RS232 (X5), Master Encoder (X7), Encoder In (X8)	Sub-D 9-pole socket (female)
I/O connectors (X3, X4)	WAGO, series 735 (cage clamp, max. 0.75 ²)
Motor connector (X9)	WAGO, series 235 (cage clamp, max. 1.5 ²)
Bus power supply connector (X10)	WAGO, series 235 (cage clamp, max. 1.5 ²)

Communication Interfaces

CAN (version AA) (Galvanically isolated, ext. supply 8..24V, max. 850mA) Important note: If 24 V _{DC} , use only a stabilized supply!	CANopen according to DS301, DSP402 max. 1 MBaud, max. 15 nodes max. cable length 40m @ 1 MBaud max. cable length 1km @ 50 kBaud
RS232	public JAT-protocol (similar to CANopen DS301) 9.6 kBaud, max. 15 nodes max. cable length 10 m
RS485 (2/4-wire) (Version LA)	public JAT-protocol (similar to CANopen DS301) 38.4 kBaud, max. 15 nodes max. cable length 400 m protocol JETWAY-R (comp. JETTER AG) max. 38.4 kBaud, max. 14 nodes max. cable length 400 m

Motor Encoder Input

Motor encoder supply	5 V DC, max. 0.2 A
Signal specification	differential TTL line driver (RS422: A, B, N, /A, /B, /N)
Input frequency	max. 2 MHz
Edge clearance	min. 0.1 µs
Pulse width	min. 0.125 µs
Galvanic isolation	none

Master Encoder Input

Master encoder supply	5V _{DC} (max. 0.2 A) or 24 V _{DC} (max. 0.1 A)
Signal specification	differential TTL line driver (RS422: A, B, N, /A, /B, /N) or 24 V signals (A, B, N)
Input frequency	max. 2 MHz
Edge clearance	min. 0.1 μs
Pulse width	min. 0.125 μs
Galvanic isolation	none

Digital Inputs

Number of inputs	10, thereof 8 programmable
Rated input voltage	24 V _{DC}
Input voltage range	20 ... 30 V
Input current	approx. 4 mA
Input resistance	5 kΩ
Input delay	appr. 1 ms
Input voltage for state "ON"	> 13 V
Input voltage for state "OFF"	< 4 V
Galvanic isolation	none

Digital Outputs

Number of outputs	3, thereof 2 programmable
Type of outputs	highside-driver to + 24 V
Rated output voltage	24 V DC
Output voltage range	20 ... 30 V
Output current	max. 0.5 A
Holding brake output	24V, max. 1.0 / 0.5 A (100 ms / continuous)
Protection circuits	against thermal overload and short-circuit to GND
Regeneration energy of inductive loads	max. 0.2J (internal Z-diodes provide fast demagnetization of inductive loads)
Galvanic isolation	none

Analog Input

Input voltage range	+/- 10 V (differential input)
Input voltage	max. 15 V
Input resistance	appr. 100 kΩ
Input delay	appr. 0.1 ms
Resolution	10 Bit
Galvanic isolation	none

CE Conformance

EMC Directive (test conditions in accordance to "EMC Installation Scheme")	pursuant to EC Directive 89/336/EEC applied harmonized standards: EN 50082.2 (Interference Immunity) EN 55011, Class B (RFI-Emission)
Low Voltage Directive	pursuant to EC Directive 73/23/EEC applied harmonized standards: EN 60204.1 / VDE113, EN 50178 / VDE160

Mechanical Outline [mm]

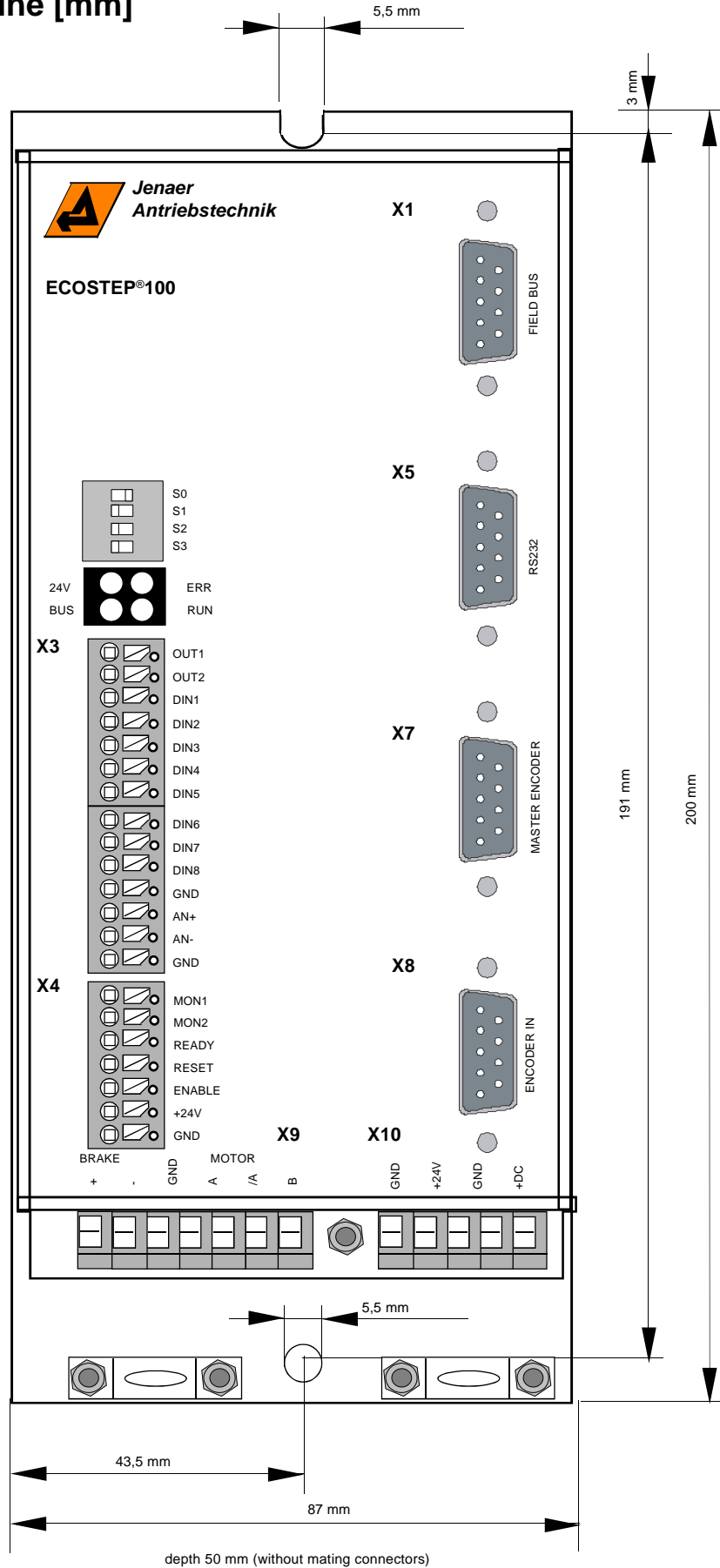

Inputs / Outputs

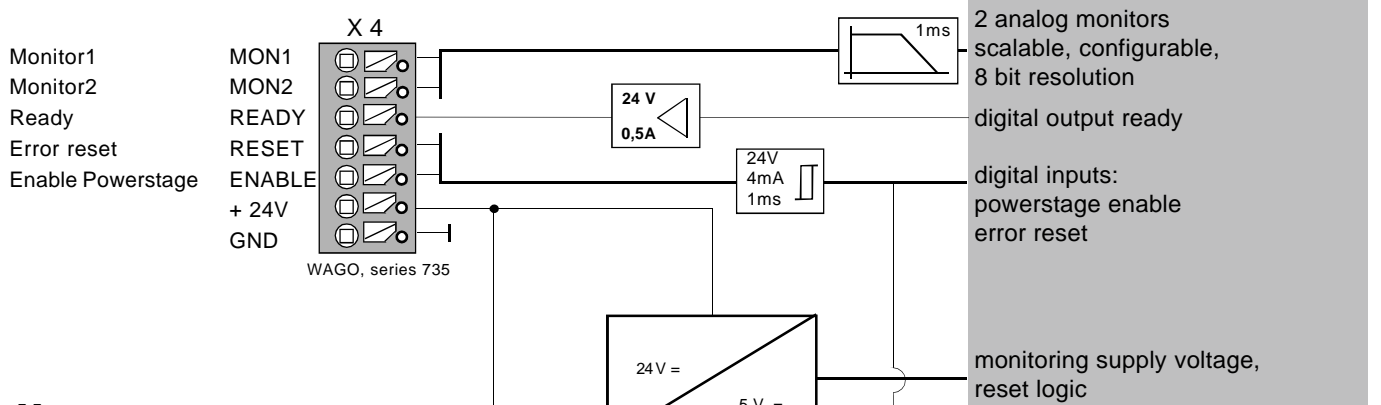
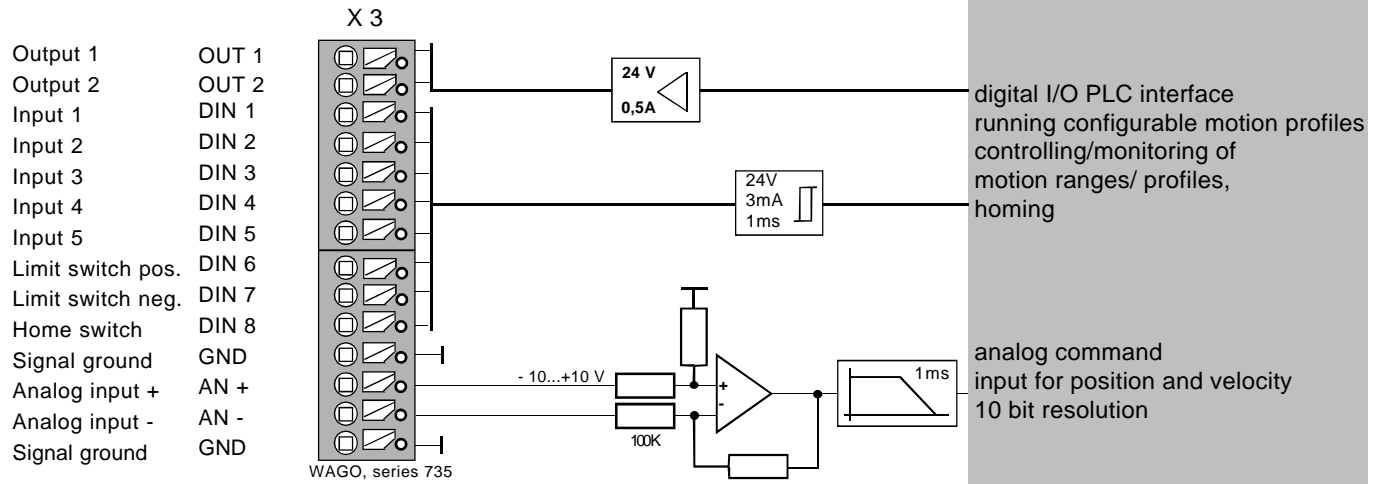

Motor

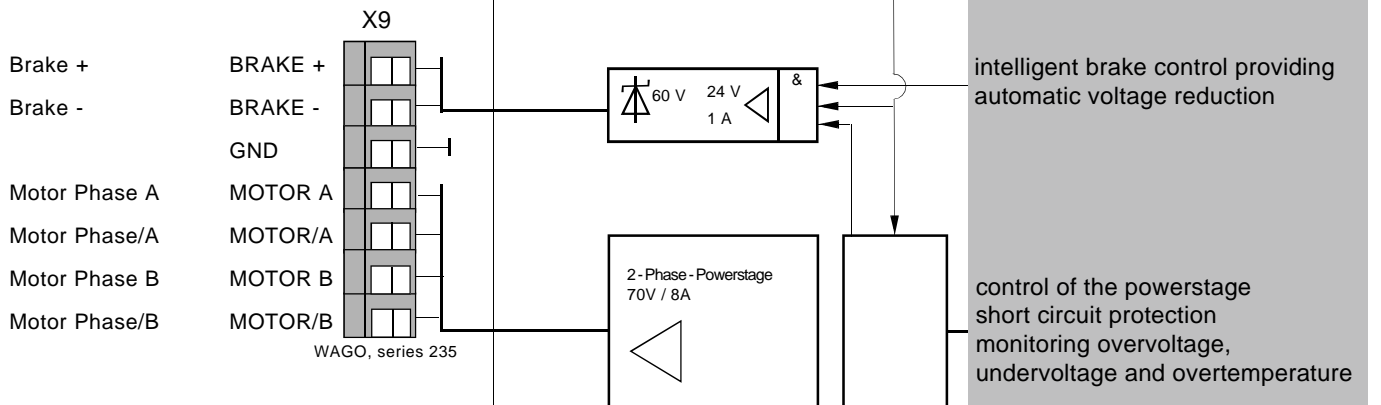

Power Supply

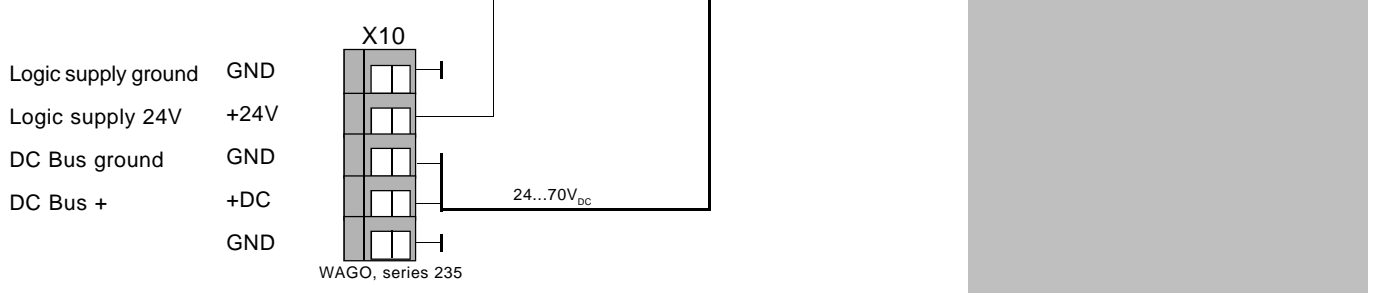

RS232 1:1 direct connection to a PC COM

RS232 serial interface for parameter setting, configuration, controlling interface for setup by a PC

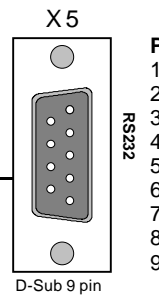

Pin	Signal at PC COM
1	DCD
2	RxD
3	TxD
4	DTR
5	GND
6	DSR
7	RTS
8	CTS
9	Ri

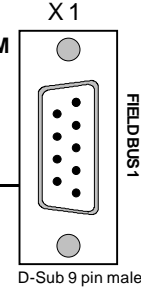

CAN

Pin	Signal
1	nc
2	CAN_L
3	CAN_GND
4	nc
5	nc
6	GND
7	CAN_H
8	nc
9	CAN_V+

Fieldbus interface CANopen, DS 402
Option: RS485

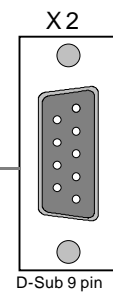
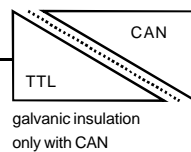

RS485

Pin	Signal
1	frei
2	Rx +
3	Tx +
4	frei
5	GND
6	+5V
7	Rx -
8	Tx -
9	frei

ID setting for serial network operation

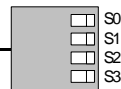

Code Switch for Network-ID

0...15

4 LEDs for indication of device status

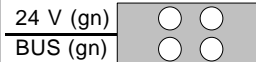

Status-LED

ERR (rd)
RUN (gn)

quadrature encoder input configurable for pulse and direction command for electronic gear functions

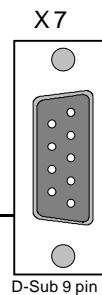
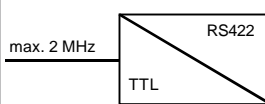

Master encoder input

Pin	Signal
1	+5V, max. 200 mA
2	A (Clock)
3	B (Direction)
4	N
5	+24V
6	GND
7	/A (/Clock)
8	/B (/ Direction)
9	/N

Optional:
absolute value encoder input (SSI)

quadrature encoder input for commutation, torque, speed and positioning control

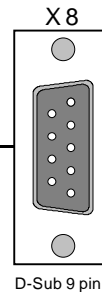
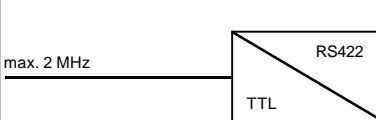

Motor encoder input

Pin	Signal
1	+5V
2	A
3	B
4	N
5	nc
6	GND
7	/A
8	/B
9	/N

Incoming Supply

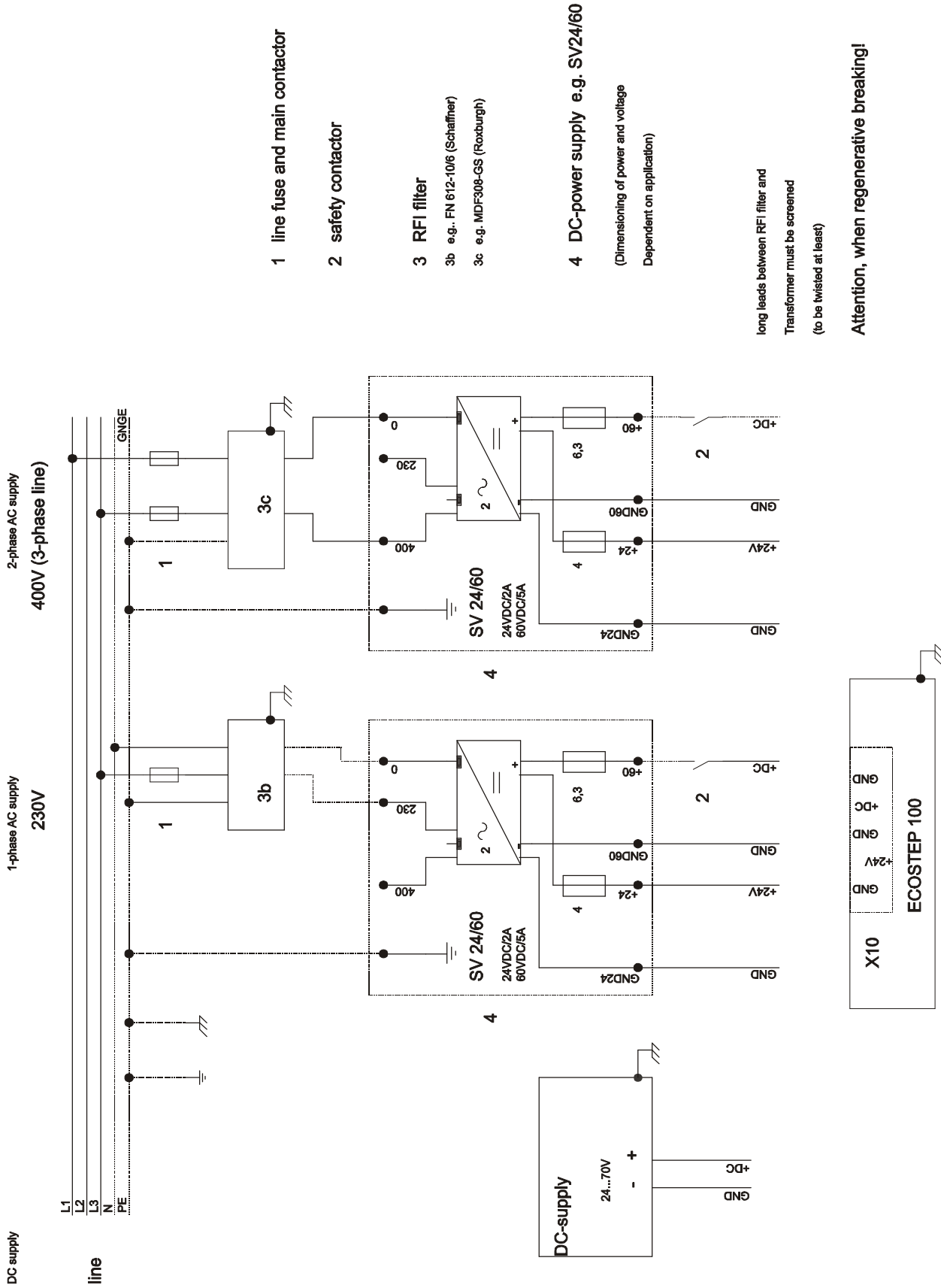

1 line fuse and main contactor

2 safety contactor

3 RFI filter

3b e.g. FN 612-10/6 (Schaffner)

3c e.g. MDF308-GS (Roxburgh)

4 DC-power supply e.g. SV24/60

(Dimensioning of power and voltage
Dependent on application)

long leads between RFI filter and
Transformer must be screened
(to be twisted at least)

Attention, when regenerative braking!

EMC Installation Scheme

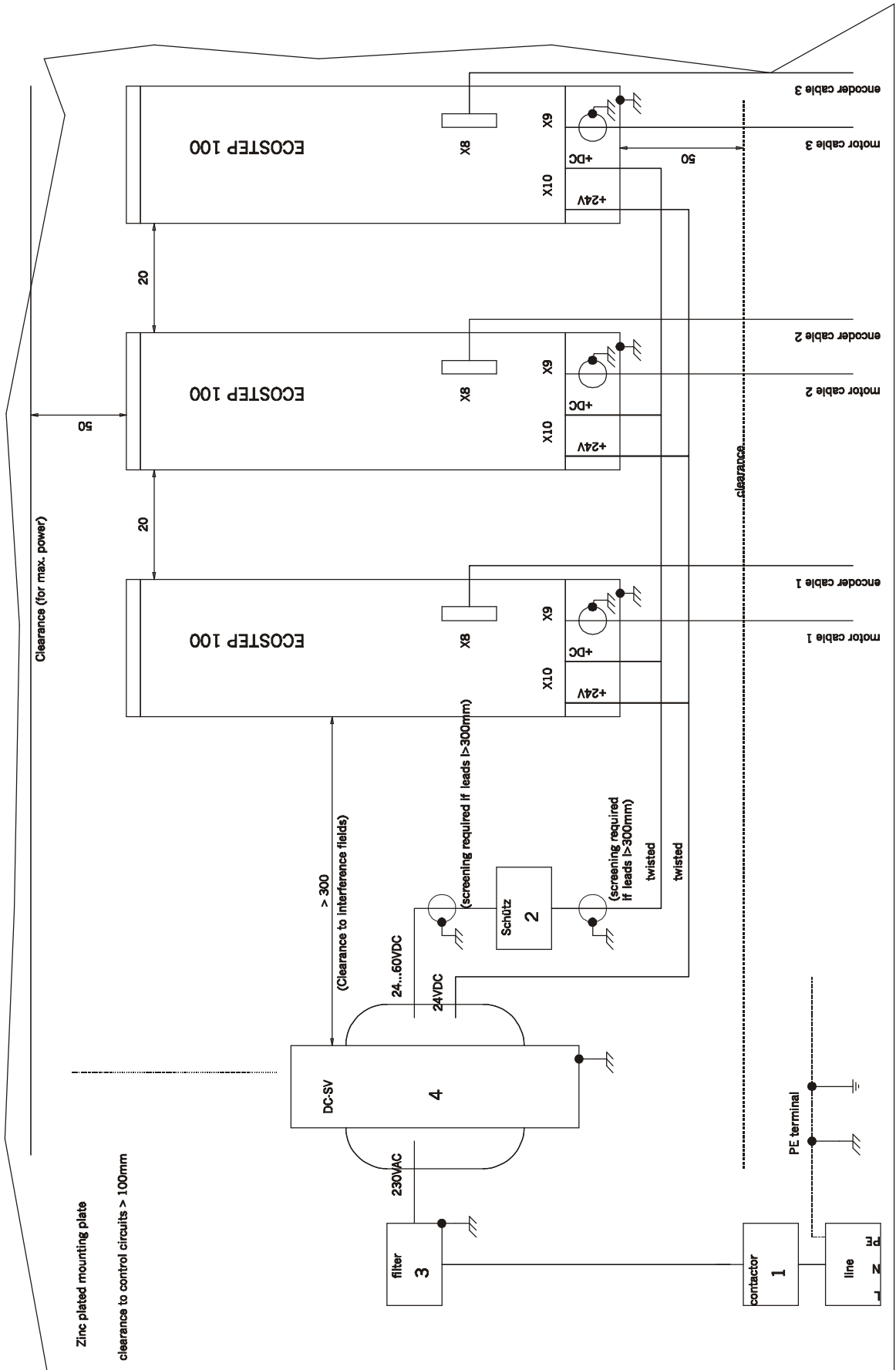

Cable Assignment

- ECOSTEP® motors series 17 (partly), 23
- ECOLIN® motors series SLM
- Motor cable MOT43

Colour	Connection ECOSTEP (X9)
Black	A
Orange	/A
Red	B
Brown /Yellow	/B
Green/Yellow	PE

- ECOSTEP® motors series 17 (partly)

Colour	Connection ECOSTEP (X9)
White	A
Yellow	/A
Red	B
Blue	/B

- ECOSTEP® motors series 34, 42
- Motor cable MOT33

Lead No.	Connection ECOSTEP (X9)
3	A
1	/A
4	B
2	/B
Green/Yellow	PE

- ECOSTEP® motors series 17 (partly), 23
- Motor / brake cable MOT34

Lead No.	Connection ECOSTEP(X9)
3	A
1	/A
4	B
2	/B
5	BRAKE+
6	BRAKE-
Green/Yellow	PE

- Brake cable BRM39

Colour	Connection ECOSTEP (X9)
Brown	BRAKE+
White	BRAKE-

- Motor Encoder Cable ENC47

Colour	Signal	Connection ECOSTEP (X9)
Red	+5V	Pin 1
Blue	GND	Pin 6
White	A	Pin 2
Brown	/A	Pin 7
Green	B	Pin 3
Yellow	/B	Pin 8
Grey	N	Pin 4
Pink	/N	Pin 9
Bare	Shield	Pin Socket

